

Roll..Profi



**einfach.
besser.
echt!**

einfach.besser.echt!

QUALITY THAT LASTS – FOR 40 YEARS.

As a family-owned company for over 90 years now, we operate with strong roots in our region and responsibility for future generations. Under the name of LÜBBERING we develop, produce and distribute „technical ideas for demanding users“ from Herzebrock in East Westphalia.

It was exactly such a technical idea that Johannes Lübbering used in 1978 to lay the foundation for the company's success: the Roll..Profi. This cable reel uncoiler – technically sophisticated and equipped with two sturdy reel bearing rollers - freed any electrician of the problem of unwinding cable reels. Tried and tested for many years, the Roll..Profi has become established as the base product in the electrical

installation. Often imitated, the cable reel roller from LÜBBERING was named as only it deserves: ORIGINAL.

Originally founded as an electrical installation company, we have now become the leading manufacturer of cable unwinding systems. With a great passion for technology and quality we are constantly developing our knowledge and skills. This is how new ideas and products of outstanding quality are created here every day – so that electrical installers all over the world can continue to entrust their rolling goods to the Roll..Profi product family.

Welcome to the Roll..Profi!

Achim Lübbering



CONTENT



Cable reel roller

ORIGINAL	max. reel width 520 mm	06 – 13
ORIGINAL XL	max. reel width 670 mm	14
ORIGINAL XS	max. reel width 220 mm	15
CONTOUR	max. reel Ø 510 mm	16 – 19
CARRYGRIP	max. reel Ø 510 mm	20 – 23



Coiled cable roller

CLOU	outer Ø up to 750 mm	26 – 32
CLOU XL	outer Ø up to 1,000 mm	33
CLOU SLIM	inner Ø 105 mm	34 – 35
CLOU FIX	fix cable coil	36 – 37
CLOU UP	standfeet	38 – 39
CLOU MOVE	castors	40 – 41
VARIO	outer Ø up to 450 mm	42 – 44
VARIO SLIM	inner Ø 95 mm	45



Large cable drum roller

JUMBO	max. drum Ø 1,800 mm	48 – 55
RAIL	max. drum Ø 1,400 mm	56 – 59



Hydraulic cable drum lifting jack

MINILIFT	up to 4,000 kg	62 – 68
JUMBOLIFT	up to 6,000 kg	69
EASYLIFT	up to 2,000 kg	70 – 73



Cable routing

FLEXIPASS	76 – 83
-----------	---------



Cable storage

CABLEDEPOT	86 – 93
------------	---------

CABLE REEL ROLLER

ORIGINAL

ORIGINALXL

ORIGINALXS

HANDLING

CONTOUR

CARRYGRIP



THERE CAN ONLY BE ONE.

The unrivalled tool for easier handling of cable reels.

For over 40 years, the ORIGINAL has been the craftsman's helper when unrolling cable reels. For daily use, we have designed a tool in solid pressure casting quality. Equipped with high-quality steel rollers, professionals know and appreciate the ORIGINAL from Herzebrock. Thanks to this quality known for decades, our ORIGINAL can withstand even the greatest strain in trade and industry – because there can only be one!

The simplicity of the implementation determines the success of an idea and thus the design of the ORIGINAL allows the product family to be expanded to meet changing market requirements. In addition to the ORIGINAL, the ORIGINAL XL with extra-wide steel rollers and the ORIGINAL XS as a small version now extend the product family of cable reel rollers.



**einfach.
besser.
echt!**

THE ORIGINAL – SINCE 1978.

Simply changing the position of the reel bearing rollers by using spring core axles at a distance allows unwinding cable reels of all sizes up to a maximum diameter of 1,200 mm. It goes without saying that our ORIGINAL offers maximum protection against dirt and corrosion because of the use of closed reel bearings that meet up to the high standards of our customers!

The anti-slip reeling-on ramp of our ORIGINAL is unique. It prevents the cable reel from slipping off during winding up. The ergonomic design with burr-free, rounded edges promotes

maximum safety to the operator. So it is the little things that make our ORIGINAL so unique – there can only be one!

Rubber feet guarantee perfect stability of the ORIGINAL and provide easy unwinding of particularly heavy reels.

Our ORIGINAL has been known for decades as a completely maintenance-free tool for use indoors or outside.

einfach.besser.echt!



Simply changing the position of the reel bearing rollers utilising internally sprung axles.



Ergonomic equipment including an anti-slip reeling-on ramp, burr-free and rounded shape promoting maximum safety to the operator.



All cable reel rollers are supplied with rubber feet. Castors can be ordered seperately.



**einfach.
besser.
echt!**

ORIGINAL

THE ORIGINAL – FOR CABLE REELS.

TECHNICAL DATA

Load-bearing capacity	200 kg
Roller gap	90, 150, 240, 300, 330 mm
Weight without castors	7.5 kg
Max. reel width	520 mm
Outer dimensions (W x L x H)	550 x 530 x 100 mm

ORDER CODE

ORIGINAL	A90101
----------	--------

ACCESSORIES

CASTORS (set = 4 pcs.)	A90301
------------------------	--------



ORIGINAL VIDEO

ORIGINAL XL

THE ORIGINAL – IN LARGE VERSION.

TECHNICAL DATA

Load-bearing capacity	200 kg
Weight without castors	9.1 kg
Max. reel width	670 mm
Outer dimensions (W x L x H)	710 x 530 x 100 mm

ORDER CODE

ORIGINAL XL	A90103
-------------	--------

ACCESSORIES

CASTORS (set = 4 pcs.)	A90301
------------------------	--------



ORIGINAL XS

THE ORIGINAL – IN SMALL VERSION.

TECHNICAL DATA

Load-bearing capacity	200 kg
Weight without castors	4.9 kg
Max. reel width	220 mm
Outer dimensions (W x L x H)	259 x 531 x 114 mm

ORDER CODE

ORIGINAL XS	A90104
-------------	--------

ACCESSORIES

CASTORS (set = 4 pcs.)	A90301
------------------------	--------



THE SOLUTION FOR DEFECTIVE DRUMS – CONTOUR ON AND DONE!

Over the last years damaged cable drums have been a recurring topic for our customers. But even if the situation often seems hopeless, we also have a simple solution for this problem with the CONTOUR. Delivered as a two-pieces-set, the CONTOUR can be used on drums with a maximum weight of 200 kg and an outer diameter of up to 510 mm.

As you already know from other Roll..Profi products, CONTOUR too is technically proven and immediately ready for use. This essential helper was designed in best quality for long-term use and has been used by our customers for over 20 years. The light construction of shockproof plastic moulding ensures a robust product.

A simple lever mechanism tensions the outer rim thereby ensuring a safe hold on drums of any kind. Only the clamping force is adjusted to the application by using the adjusting screw and one handle later the drum can be easily uncoiled on our ORIGINAL as usual.

Always with an eye on operational safety, we offer a solution that enables our customers to use their existing unwinding systems.

With our CONTOUR you can also use damaged cable drums without any problems on our long proven Roll..Profi ORIGINAL - You do not need a new uncoiler, just a good idea!



Place a CONTOUR wheel on the outside of the assembled cable drum. Now, switch the lever. This activates the inner tension care and the CONTOUR wheel is tightened to the drum.



CONTOUR

THE SAFETY WHEEL FOR DAMAGED CABLE REELS.

TECHNICAL DATA

Max. drum weight	200 kg
Max. drum Ø	510 mm
Holding capacity outer rim	55 – 62 mm

ORDER CODE

CONTOUR (Set = 2 pcs.)	A90501
------------------------	--------

ACCESSORIES

Large capacity outer rims Ø 79 mm (Set = 2 pcs.)	A9050112
Holding capacity outer rim	79 – 94 mm



 CONTOUR VIDEO

CARRYGRIP – CARRYING REELS AS PROFESSIONALS WOULD.

Whether loading, carrying, laying down or setting up at the operational site – cable reels are unwieldy and don't make your work easy.

Now CARRYGRIP is the perfect assistant for all these situations and you have your cable reel always firmly under control. This manual carrying system is ready for use in seconds: In just a few steps, the tensioning unit is adjusted to the appropriate drum size and locked – and so you can transport together with your colleague a load of up to 100 kg safely and without hurting

your back. CARRYGRIP also is an indispensable and reliable helper when setting up and laying down cable drums: Using the sturdy single handle, you can easily and safely lever your cable reel with minimal effort into the desired position.

CARRYGRIP is delivered in a set of 2 and in best Roll..Profi quality – for long-lasting use and professional work. The manual carrying system CARRYGRIP offers you everything you need for flexible, ergonomic and safe handling of reels on the construction site.



Hook the carriers of the CARRYGRIP into the cable reel.



Loosen the clamping lever and guide the clamping unit to the edge of the cable reel.



Tighten the clamping lever at the edge of the cable reel by pressing down.



**einfach.
besser.
echt!**

CARRYGRIP

THE TEAM PLAYER FOR MORE ATTITUDE

TECHNICAL DATA

Reel Ø	max. 600 mm*
Load per system	max. 50 kg
Load two systems	max. 100 kg

ORDER CODE

CARRYGRIP (1 set = 2 pcs.)	A90801
----------------------------	--------

*Depending on the diameter of the inner hole



CARRYGRIP VIDEO



Not far from
the Teutoburg Forest and
the Hermann Monument,
every day we create outstanding
ideas for companies
all over the world.

COILED CABLE ROLLER

CLOU

CLOU^{XL}

CLOU^{SLIM}

VARIO

VARIO^{SLIM}



AS STEADY AS FLEXIBLE.

Impressive variety of the giant performer: The CLOU family – ready for use for the most diverse pipe and cable coils.



For 25 years the absolute number one when it comes to unwinding ring goods. No matter whether cables and wires, empty tubes, chains or steel cables, the CLOU keeps its promises. The professional device can carry up to 80 kilograms and it makes no difference whether the ring goods are in a cardboard box, in foil or even without packaging. It can even handle cable giants like 5 x 25 sqmm or ring diameters of 750 mm. Only because of the CLOU's proven unwinding

technology, it is possible to uncoil the rolled goods from the center of a coil without twisting. This is exactly what has led to the CLOU becoming a master of its kind and so appreciated by our customers.

No wobbling, no rattling and no plastic. Set up in just a few steps, the CLOU is ready for unwinding.

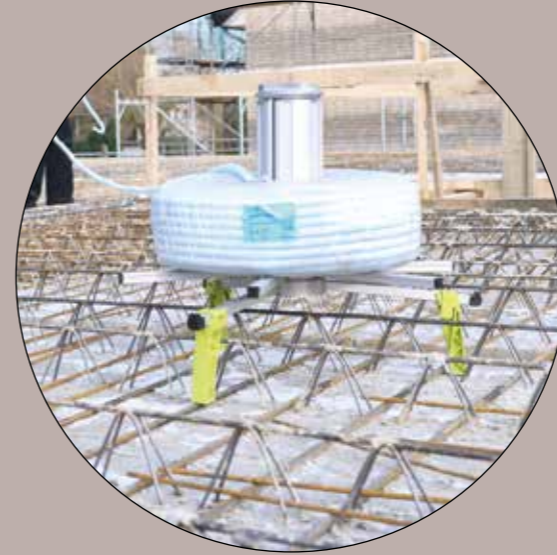

THE CLOU FAMILY – A CLEVER SOLUTION FOR EVERY PROBLEM.

The CLOU shrinks to a very small size and so the giant performer turns into a toddler through perfect technology. It disappears into the carrier bag that is included in product delivery, needs minimum storage space and is always ready for use. If it gets really big, the CLOU XL helps and so even coils with a diameter of 1 meter can be uncoiled easily. The CLOU family also has a solution for coils with a small inner diameter – the CLOU SLIM with a narrow core. All designs are foldable, delivered with a carrier bag and all the advantages of the CLOU family.

Of course there are also accessories that make our products so unique:

- CLOU UP for optimum standing on the bare floor
- CLOU MOVE for quick changes of location
- CLOU FIX if the coil lacks posture

As with all Roll..Profi products, the CLOU has a maintenance-free design and guarantees safe handling indoors as well as outdoors.



Quickly unfolded



Quickly folded



With practical carrier bag



THE OPTIMAL UNWINDING TOOL FOR ALL COIL PRODUCTS.

TECHNICAL DATA

Load-bearing capacity	80 kg
Coil Ø	750 mm
Core Ø	min. 150 mm max. 260 mm
Core height	350 mm
Working field	800 x 800 mm
Storage capacity (Ø, H)	170 mm, 455 mm
Weight	7.5 kg

ORDER CODE

CLOU incl. carrier bag	A90220
------------------------	--------

ACCESSORIES

CLOU FIX (Set = 3 pcs.) incl. carrier bag	A90225
CLOU UP (Set = 3 pcs.)	A90226
CLOU MOVE (Set = 3 pcs.)	A90230



THE UNWINDING MASTER FOR LARGEST COIL GOODS.

TECHNICAL DATA

Load-bearing capacity	80 kg
Coil Ø	max. 1,000 mm
Core Ø	min. 150 mm max. 260 mm
Core height	500 mm
Working field	1,100 x 1,100 mm
Storage capacity (Ø, H)	165 mm, 605 mm
Weight	9.5 kg

ORDER CODE

CLOU XL incl. carrier bag	A90221
---------------------------	--------

ACCESSORIES

CLOU FIX (Set = 3 pcs.) incl. carrier bag	A90225
CLOU UP (Set = 3 pcs.)	A90226
CLOU MOVE (Set = 3 pcs.)	A90230



THE SLIM UNCOILER FOR SMALL COIL GOODS.

TECHNICAL DATA

Load-bearing capacity	80 kg
Coil Ø	750 mm
Core Ø	105 mm
Core height	300 mm
Working field	800 x 800 mm
Storage capacity (Ø, H)	165 mm, 420 mm
Weight	5.5 kg

ORDER CODE

CLOU SLIM incl. carrier bag	A90224
-----------------------------	--------

ACCESSORIES

CLOU FIX (Set = 3 pcs.) incl. carrier bag	A90225
CLOU UP (Set = 3 pcs.)	A90226
CLOU MOVE (Set = 3 pcs.)	A90230



THE ACCESSORIES, IF THE RING LACKS POSTURE.

TECHNICAL DATA

Storage capacity (L x W x H)	30 x 160 x 87 mm
Weight per piece	100 g

ORDER CODE

CLOU FIX (Set = 3 pcs.) incl. carrier bag	A90225
---	--------

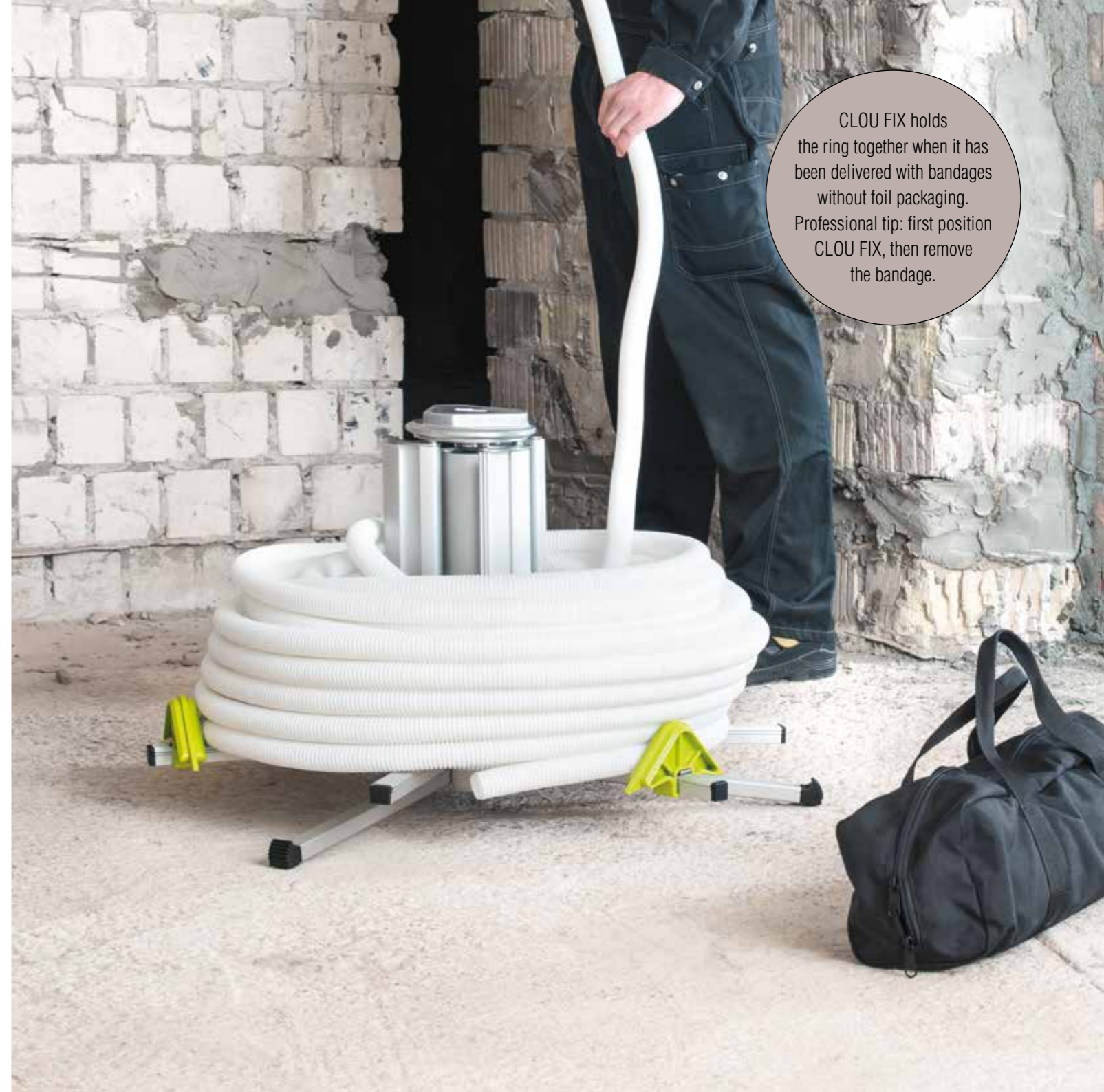

CLOU FIX holds the ring together when it has been delivered with bandages without foil packaging. Professional tip: first position CLOU FIX, then remove the bandage.



THE ACCESSORIES FOR OPTIMUM STANDING ON THE BUILDING SHELL.

TECHNICAL DATA

Dimensions (L x W x H)	52 x 63 x 157 mm
Weight per piece	165 g

ORDER CODE

CLOU UP (Set = 3 pcs.)	A90226
------------------------	--------

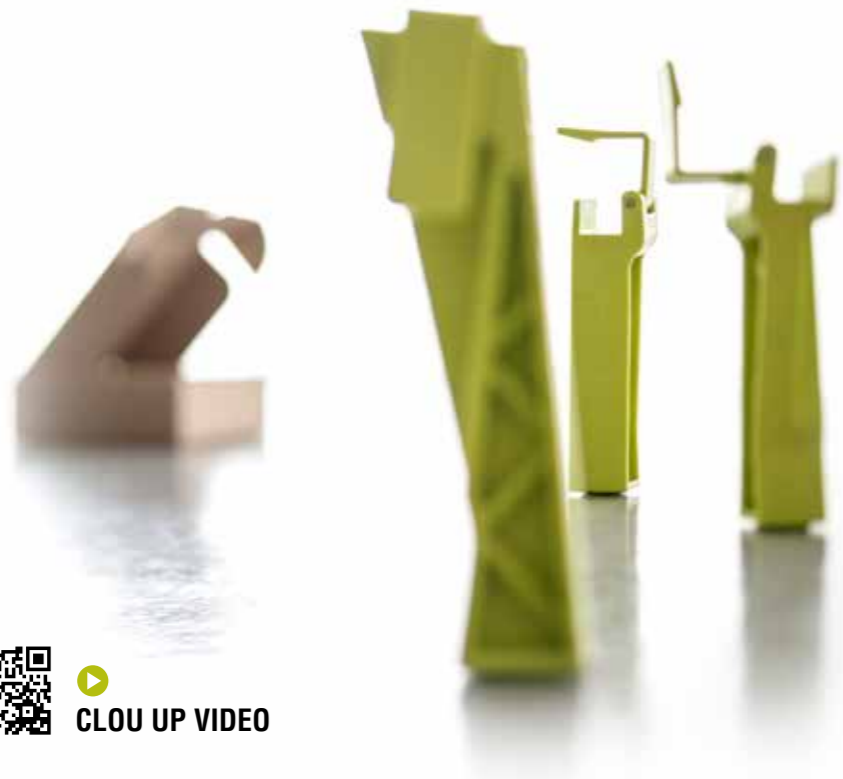

CLOU UP brings the CLOU where it belongs: over the reinforcement!

Small accessories, big impact.



CLOU UP VIDEO

THE ACCESSORIES FOR QUICK CHANGES OF LOCATION.

TECHNICAL DATA

Dimensions (H x W)	152 x 77 mm
Weight per piece	1 kg

ORDER CODE

CLOU MOVE (Set = 3 pcs.)	A90230
--------------------------	--------



 CLOU MOVE VIDEO

THE VARIO FAMILY.

The VARIO Family – the flexible solution for smaller units.

For almost 40 years the VARIO is well-known for professional cable coil processing. Initially equipped with a red frame, for years now the VARIO has been rolling over construction sites all over the world in fresh green. Valued by operators installing cables with smaller cross-sections.

Two different versions are available. From the center of the 300 mm high core and with a minimum diameter of 150 mm the

VARIO can de-reel all sorts of cables without twisting them. The adjustable core can be adapted to the cable coil and thus creates optimal unwinding conditions.

With the VARIO SLIM we offer you a solution for coils with particularly small inner diameters. Both ring uncoilers have been tested for use on the construction site, in workshop trucks and in warehouses.



VARIO

THE MOBILE UNWINDING TOOL FOR CABLE COILS.

TECHNICAL DATA

Unwinding plate \varnothing	450 mm
Core \varnothing	min. 150 mm max. 260 mm
Core height	300 mm
Reception Rack (W x L)	510 x 460 mm
Overall height	530 mm
Load-bearing capacity	50 kg
Weight	13.5 kg

ORDER CODE

VARIO incl. Castors (Set = 4 pcs.)	A90206
------------------------------------	--------



VARIO SLIM

THE SOLID CLASSIC FOR SMALL INNER DIAMETERS.

TECHNICAL DATA

Unwinding plate \varnothing	450 mm
Core \varnothing	95 mm
Core height	300 mm
Reception Rack (W x L)	510 x 460 mm
Overall height	530 mm
Load-bearing capacity	50 kg
Weight	11 kg

ORDER CODE

VARIO SLIM incl. Castors (Set = 4 pcs.)	A90207
---	--------



 VARIO VIDEO



Family-owned for
over 90 years, we operate
with strong roots in our region
and responsibility for
future generations.

LARGE CABLE DRUM ROLLER

**JUMBO
RAIL**

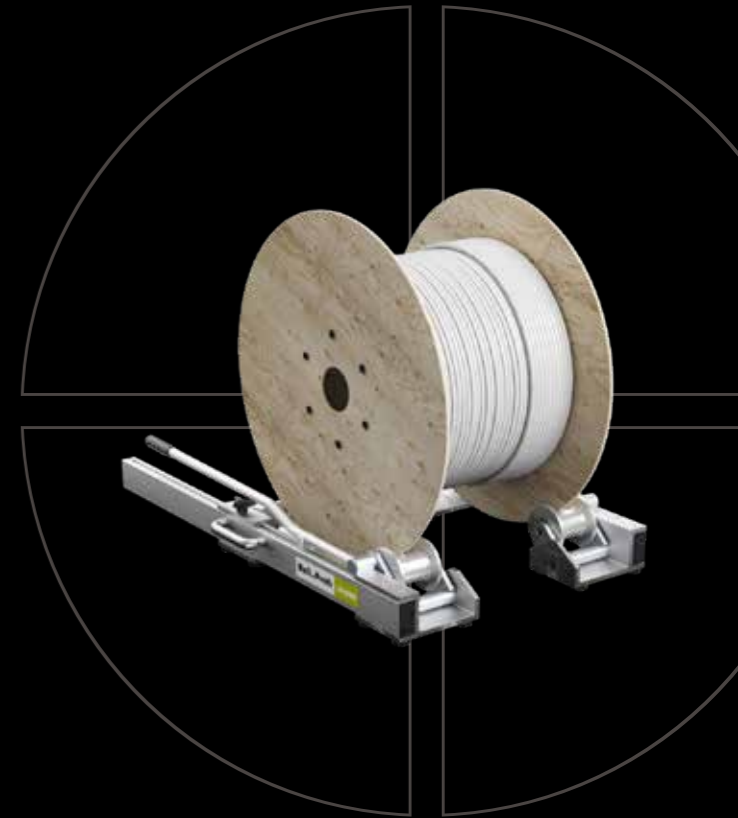

HEAVY WEIGHTS EASILY DONE.

With our large cable drum rollers you can even safely uncoil heavy cable goods.

Roll..Profi large cable coilers are used where, for example, different cable types on large drums are to be processed next to each other. The flexibility due to quick and easy change from drum to drum makes the JUMBO and the RAIL reliable partners for the heavyweights among the drums.

Of course our large cable drum rollers fulfil the highest demands on load capacity and stability. However, as every professional knows, the unwinding process directly depends on the quality of the cable drum.



**einfach.
besser.
echt!**

CLEVER TECHNOLOGY FOR EASY HANDLING OF LARGE DRUMS.

The quick and easy change from drum to drum makes the JUMBO so interesting. The JUMBO will only be brought into action at the place where it is needed.

The drum with a maximum diameter of 1.80 metres can be transported to the site of operation by forklift truck or rolled by hand. Place the two parts of the JUMBO on the right and left side of the cable drum.

Then adjust the movable counter rollers according to the diameter of the cable drum and press the cable drum with the technically simple lever mechanism with little effort into the unwinding position.

The all-metal design, stable aluminium-steel construction with maintenance-free ball bearings, ensures a long service life.



Adjust the movable counter rollers according to the drum's diameter.



Raise the drum into its unwinding position.



Now, your drum is ready for use.



**einfach.
besser.
echt!**

JUMBO

SIMPLE AND FLEXIBLE – THE BIG ONE AMONG THE LARGE CABLE ROLLERS.

TECHNICAL DATA

Total Load-bearing capacity	1,500 kg
Recommended max. rolling weight for wooden drums*	700 kg
Drum Ø	min. 500 mm max. 1,800 mm
Width	277 mm
Length	1,206 mm
Height	195 mm
Weight per element	17 kg

ORDER CODE

JUMBO	A90102
-------	--------

*Due to the sometimes poor condition of wooden drums, we recommend not to exceed the unwinding weight of 700 kg for easier handling.



 JUMBO VIDEO

THE COMPACT ONE FOR HANDLING LARGE DRUMS.

The RAIL is the uncoiler for drums up to 1.40 metres diameter. Equipped with high-quality, ball-bearing support rollers, the RAIL is your reliable unwinding tool even for heavy cable products. The two unwinding RAIL must be positioned parallel to each other in front of the drum flanges. The swivelling rollers

can subsequently be adjusted to the diameter of the cable drum by simply moving them into position. Now, the drum can be rolled over the ramp onto the ready to use RAIL. The cable drum can be removed by locking the respective supporting roller and after that the drum can be rolled out of the RAIL.



The swivelling rollers can subsequently be adjusted to the diameter of the cable drum by simply moving them into position.

To roll up and unroll the drum lock the front supporting rollers.



**einfach.
besser.
echt!**

RAIL

COMPACT AND STURDY – THE SMALL ONE AMONG THE LARGE CABLE DRUM ROLLERS.

TECHNICAL DATA

Total Load-bearing capacity	1,500 kg
Recommended max. rolling weight for wooden drums*	700 kg
Drum Ø	min. 500 mm max. 1,400 mm
Width	160 mm
Length	903 mm
Height	120 mm
Weight per element	9 kg

ORDER CODE

RAIL	A90105
------	--------

*Due to the sometimes poor condition of wooden drums, we recommend not to exceed the unwinding weight of 700 kg for easier handling.



 RAIL VIDEO



The passion for technology is a culture that is supported and lived by every employee.

We pursue ideas as usual in East Westphalia: stubborn, persistent and combative.

We are very proud of it!

HYDRAULIC CABLE DRUM LIFTING JACK

MINILIFT
JUMBOLIFT
EASYLIFT



POWER PACKS LIFTING THE DRUMS.

Innovative, resilient and unique: the perfect solution for professional drum handling.

Cable drums with a weight up to 6 t and a maximum diameter of 2.20 meters pose a special challenge in everyday work. The requirements for unwinding such weights are maximum stability and maximum safety. That is why professionals have been opting for our high-performance drum lifters for years. The main advantages of our drum lifters are the mounting blocks that are equipped with floating bearings as well as the centering cones on the drum axle. This guarantees an absolutely smooth

and quiet running and reduces the risk of the entire system tipping over.

Each drum lifter is provided as a package consisting of 2 side parts, a drum axle and the corresponding centering cones – and is therefore – as you would expect from a Roll..Profi product – immediately ready for use.



**einfach.
besser.
echt!**

THE HIGH-END DRUM LIFTS MINILIFT AND JUMBOLIFT.

These drum lifters from Herzebrock are absolute professionals for use on the construction site. Stable and equipped with a chassis for flexible use, they ensure safe handling of all large cable drums up to a weight of 6 t and 2.20 m in diameter.

The strength of our drum lifters is their easy handling: First, fix the cable drum on the drum axle using the centering cones.

Place the movable sides of the drum lifter next to the cable drum. Now snap the adjustable mounting block into the guide profile at the height of the drum axle. By simply pumping, you hydraulically lift your cable drum and lock the retaining rings underneath the cross beam. Now lower your lift system using the set screw on the hydraulic jack. Thus your lift system is safe and stable for your use.

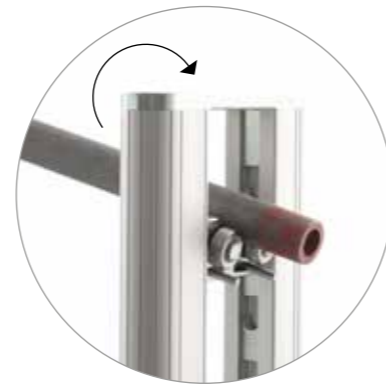

Height adjustability and compensation for uneven floors.



**einfach.
besser.
echt!**

MINILIFT

THE POWERFUL HYDRAULIC CABLE DRUM LIFTING JACK UP TO 4 TONS.

TECHNICAL DATA

Max. load	4,000 kg
Max. drum Ø	1,600 mm
Min. drum Ø	650 mm
Dimensions (H x D x W)	863 x 358 x 450 mm
Length of drum axle	1,500 mm
Max. drum width	1,000 mm
Weight per side	40 kg

ORDER CODE

MINILIFT Set: A90112

- two side parts
- one drum axle 1,500 mm
- one Set centering cones Ø 95 mm

ACCESSORIES

Drum axle 1,850 mm	A9012060
Set centering cones Ø 140 mm	A9012083



MINILIFT VIDEO

JUMBOLIFT

THE POWERFUL HYDRAULIC CABLE DRUM LIFTING JACK UP TO 6 TONS.

TECHNICAL DATA

Max. load	6,000 kg
Max. drum Ø	2,200 mm
Min. drum Ø	700 mm
Dimensions (H x D x W)	1,122 x 440 x 500 mm
Length of drum axle	1,850 mm
Max. drum width	1,300 mm
Weight per side	70 kg

ORDER CODE

JUMBOLIFT Set: A90121

- two side parts
- one drum axle 1,850 mm
- one Set centering cones Ø 95 mm
- one Set centering cones Ø 140 mm

ACCESSORIES

Drum axle 1,500 mm	A9011032
--------------------	----------



JUMBOLIFT VIDEO

EASYLIFT – THE ENTRY-LEVEL MODEL FOR EASY DRUM HANDLING.

Our new drum lifter is the ideal solution for all those who want to easily handle medium-sized drums. Stable and flexibly positionable, the EASYLIFT guarantees safe handling of cable drums up to a weight of 2 t and 1.20 m in diameter on level ground.

Our EASYLIFT too offers the familiar easy handling of a Roll..Profi product: Start by fixing the cable drum onto the drum

axle using the centering cones. Place the side parts of the EASYLIFT next to the cable drum. Adjust the mounting block to the height of the drum axle and secure it with the locking bolts. By simply pumping, you can hydraulically lift your cable drum and secure it with the locking bolts. You benefit from the philosophy of the Roll..Profi here as well. All parts are secured against loss. With the adjusting screw on the hydraulic jack you can now lower your EASYLIFT into the unwinding position.



Easy and safe adjustment of height by using the safety device.



**einfach.
besser.
echt!**

EASYLIFT

THE SMALL HYDRAULIC CABLE DRUM LIFTING JACK UP TO 2 TONS.

TECHNICAL DATA

Max. load	2,000 kg
Max. drum Ø	1,200 mm
Min. drum Ø	600 mm
Dimensions (H x D x W)	640 x 250 x 450 mm
Length of drum axle	1,350 mm
Max. drum width	850 mm
Weight per side	26 kg

ORDER CODE

EASYLIFT Set: A90122

- two side parts
- one drum axle
- Set centering cones

ACCESSORIES

Drum axle 1,500 mm A9011032



 EASYLIFT VIDEO

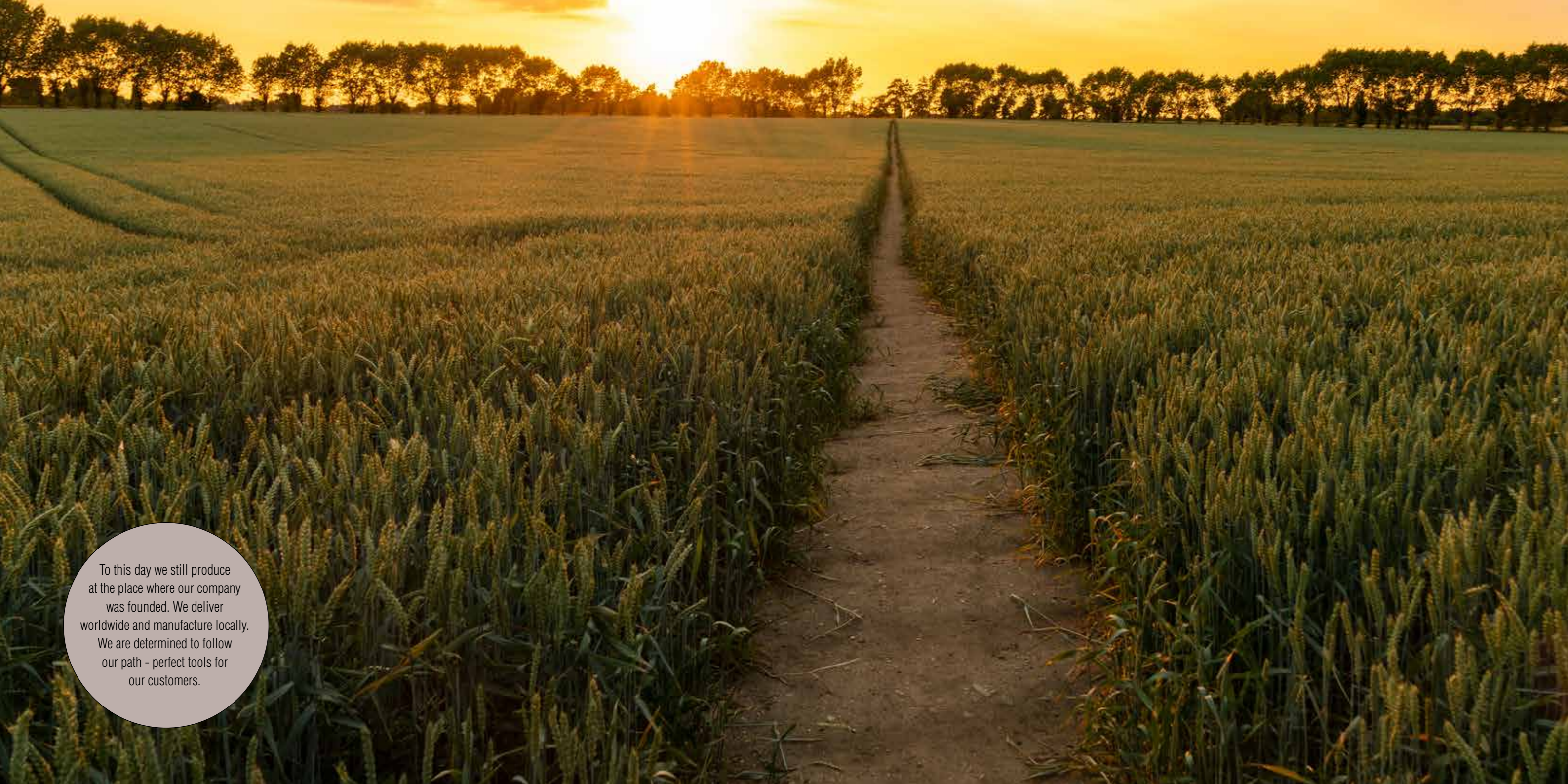

To this day we still produce at the place where our company was founded. We deliver worldwide and manufacture locally. We are determined to follow our path - perfect tools for our customers.

CABLE ROUTING

FLEXIPASS



SIMPLY CLEVER THOUGHT AROUND THE CORNER.

The innovative cable routing system from Roll..Profi.



reddot winner 2021



For almost all cable routings, the prevention of material damage is the top priority, especially for sensitive data cables.

Channel curves and differences in height can further complicate the cable pulling. Commercially available deflection products are often complicated and time-consuming to assemble and dismantle. From now on, our FLEXIPASS offers the optimal solution: handy, flexible and immediately ready for use.

With its ergonomic and compact design and smooth-running guide rollers, FLEXIPASS ensures safe and precise cable transfer at all corners and edges of cable trays.

Packed in a professional bag, the basic set consists of three FLEXIPASS. This guarantees a maximum of flexibility at first use immediately. Furthermore, you can add more FLEXIPASS to your cable management system at any time.



FLEXIPASS – QUICK AND EASY CABLE ROUTING FOR PROFESSIONALS.

Our FLEXIPASS is the universal cable routing system for all kinds of cable trays. The FLEXIPASS can be used for cables up to a diameter of 38 mm. Our focus lies on handling sensitive data and special cables. The clever arrangement of the rollers ensures optimal and resistance-free cable routing and transport.

With its low own weight of 0.75 kg, the FLEXIPASS can be used even on light cable trays without any problems.

It's that simple: Place the FLEXIPASS on the cable tray and fix it quickly and easily with the one-hand clamping mechanism. The FLEXIPASS holds with its rubberised clamping surfaces without cumbersome screwing – no slipping, no tilting. Now insert the cable, secure with the latch and the FLEXIPASS is ready to uncoil.

Even releasing the FLEXIPASS is a child's play. This will save valuable time when assembling and dismantling the cable routing system.



Push



Span



Loosen



**einfach.
besser.
echt!**

THE PRACTICAL ALL-ROUNDER FOR SECURE CABLE ROUTING.

TECHNICAL DATA

Max. cable Ø	38 mm
Max. clamping width	48 mm
Weight per piece	850 g
Width (widest point)	65 mm
Length	331 – 379 mm
Height	148 mm

ORDER CODE

FLEXIPASS (Set = 3 pcs.) incl. carrier bag	A90229
FLEXIPASS (single)	A9022940

ACCESSORIES

Stand	A9022925
-------	----------



**einfach.
besser.
echt!**



 FLEXIPASS VIDEO



One never reaches home,
but where friendly paths cross,
the whole world looks like
home for a while.

Hermann Hesse

CABLE STORAGE

CABLEDEPOT

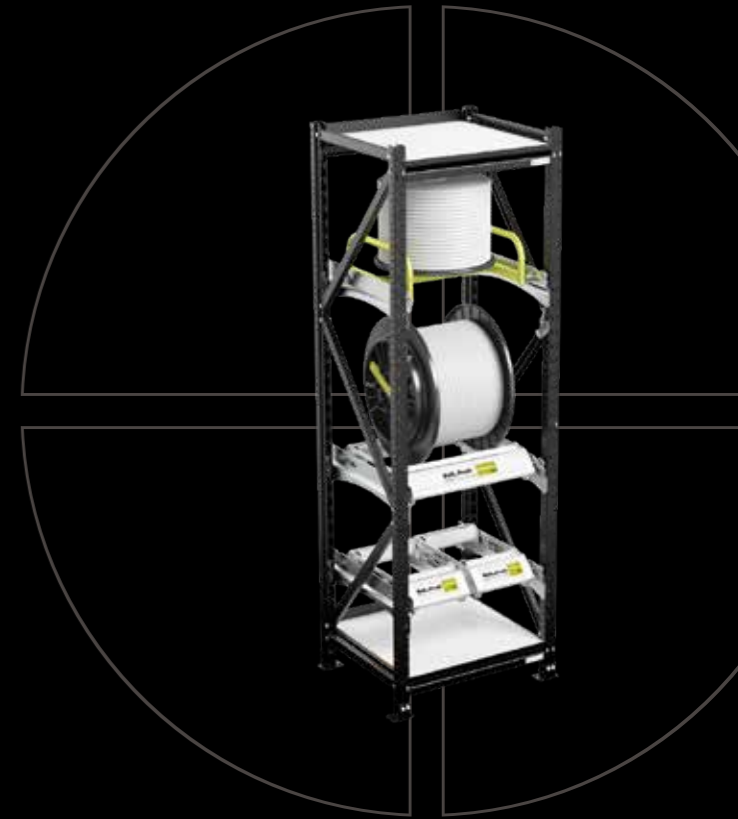

FLEXIBLE STACKING WITH SYSTEM.

The new modular storage system for the Roll..Profi.

On the market there already is a wide range of storage systems for cables and wires. However taking a closer look, it soon will be clear that no practicable solutions can be found, particularly for the storage of small drum and ring products.

With the new cable storage system from Roll..Profi, we offer you a suitable solution: the CABLEDEPOT.

This infinitely expandable system does not end with the storage of cable rings and drums – storage shelves in different lengths are also part of the CABLEDEPOT's range of products. Modules

for worktops are also available and expand your range of uses. With the CABLEDEPOT you are not limited on a rigid division. It allows you a flexible use at any time.

Decide today at which place which pipe is stored and simply reorganize the placing the next day. It is only the height we determine: CABLEDEPOT is available in a maximum height of 2 m. The reason: Your safety is important to us. The CABLEDEPOT is firmly screwed to the floor and does not require a wall bracket.

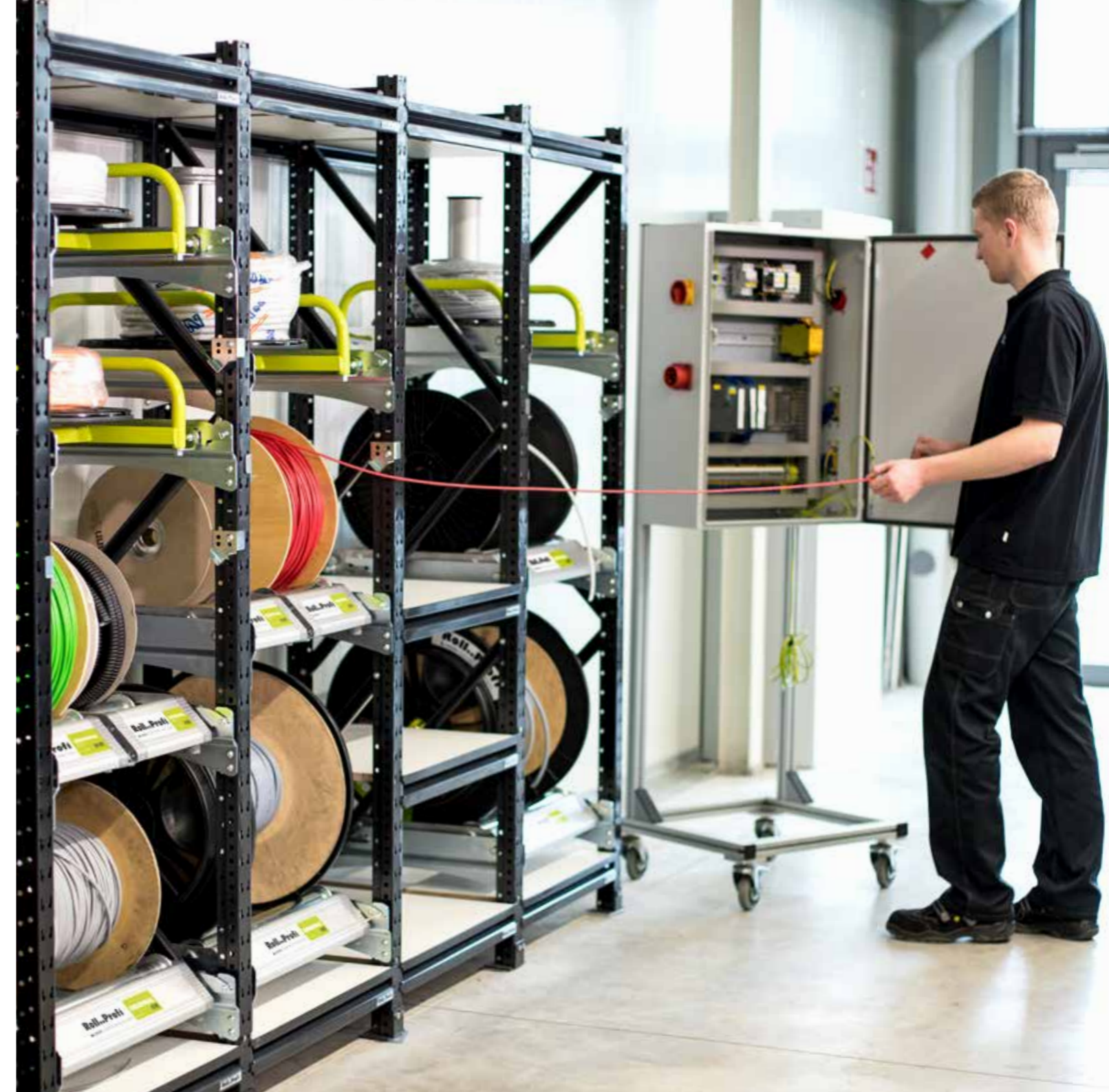

CABLEDEPOT – AS UNIQUE AS FLEXIBLE.

Facts for professionals:

- Cable coils with a minimum inner diameter of 95 mm
- Cable coils with a maximum weight of 50 kg
- Cable coils with a maximum outer diameter of 450 mm
- Cable drums with a maximum width of 520 mm
- Cable drums with a maximum weight of 140 kg

with the ORIGINAL DUO: With this, two smaller drums can be uncoiled on the same width of the original.

We also have implemented a clever idea for loading ring uncoilers: The uncoiler is pulled forward and lowered in its support rail. This way the ring can be put on easily.

As in any warehouse, space is the decisive resource for the CABLEDEPOT too. We offer a particularly space-saving solution



All uncoilers are secured against falling out.



Position for easy loading of the cable coils uncoilers.



position of the supportrails is flexible and quickly adjustable.

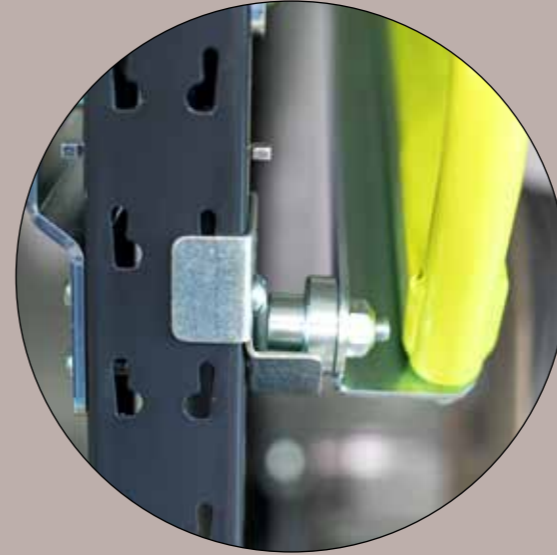

**einfach.
besser.
echt!**

ONE SYSTEM – COUNTLESS STORAGE POSSIBILITIES.

We will not leave you alone with the planning of your CABLEDEPOT. Together we can find the best solution for you out of all available options.

Please feel free to contact our friendly service staff with sizes of your available space and an approximate number of rings or drums. In cooperation with you we would be pleased to take over the planning for your CABLEDEPOT.

For detailed information please, contact our specialists on:

Fon: +49 (52 45) 83 09-374

Fax: +49 (52 45) 83 09-274

info@rollprofi.de

www.rollprofi.de

Or simply configure online:

konfigurator.rollprofi.de



NOTES

.....

www.rollprofi.de

LÜBBERING ABROLLSYSTEME GMBH & CO. KG
Hans-Böckler-Straße 9
33442 Herzebrock-Clarholz
GERMANY

Fon: +49 (52 45) 83 09-374
Fax: +49 (52 45) 83 09-274
info@rollprofi.de

www.rollprofi.de
© rollprofi

Luebbering (UK) Ltd.
www.luebbering.co.uk

Luebbering France
www.luebbering.de

Luebbering Corp. USA
www.luebbering.com

Lübberring China
www.luebbering.de

